



# 4XD

SUBMERSIBLE 4" NON-CLOG EXPLOSION PROOF SEWAGE PUMP

### FEATURES

**Impeller:** Cast iron, two vane closed design for high efficiency and maximum wear life. Balanced for smooth operation. Optional bronze impeller available.

**Bronze Wear Ring:** Replaceable to renew the running clearances and efficiencies to original conditions.

**Casing:** Heavy duty cast iron, volute type for maximum efficiency. 4" 125# ANSI cast iron flanged. Adaptable to guide rail mounting system.

**Tandem Seals:** Two independently mounted mechanical face type seals are separated by an oil filled chamber. The oil chamber acts as a barrier to trap moisture and provide time for a planned shutdown and maintenance. The oil provides lubrication to the internal (upper) seal. Carbon rotating and ceramic stationary faces are standard on both internal (upper) and external (lower) seals. Optional materials are available for the lower seals. See the Nomenclature Page for order number changes to order either silicon carbide/silicon carbide faces with Viton or silicon carbide/tungsten carbide faces with Viton elastomers. These are recommended for applications containing fine solids or abrasives as found in parking lot/garage drainage and construction dewatering jobs.

### APPLICATIONS

Heavy duty design features for a wide range of commercial and industrial applications such as:

- Sewage systems
- Flood and pollution control
- Industrial dewatering
- Wastewater treatment plants
- Municipal and subdivision lift stations

### SPECIFICATIONS

#### Pump:

- Solids handling capabilities: 3" maximum.
- Discharge size: 4" 125# ANSI flanged.
- Capacities: up to 1160 GPM.
- Total heads: up to 140 feet.
- Minimum flow: 100 GPM.
- Maximum flow: end of published curve.
- Mechanical seals: 304 stainless steel metal parts, BUNA-N elastomers with carbon/rotary and ceramic/stationary faces standard for upper and lower seals. Optional lower seals are available with Viton elastomers and either silicon carbide/silicon carbide or silicon carbide/tungsten carbide faces.
- Fasteners: 300 series stainless steel

#### Motor:

- **Explosion Proof Motor:** Motors up to and including 40 HP are rated as Class F, 1.15 service factor and are certified explosion proof for Class I, Division I, Groups C and D locations.
- CSA certified motors (Canadian Standards Association).

**Moisture Protection System:** Two-wire, dual moisture sensing probes are located in the oil filled chamber between the inner and outer seals. When connected to a control panel with an optional Moisture Detection System and an alarm it will detect the presence of moisture should the outer seal fail. It will also detect moisture in the motor chamber and provide a warning prior to water levels reaching the bearing or stator.

**Designed for Continuous Operation:** Motor is rated continuous duty submerged condition in water that is 40° C or below. Maximum runtime with pump unsubmerged for 7½-40 HP is 15 minutes. Motor is suitable for 10 starts per hour.

**Bearings:** Ball, single-row, angular contact, Conrad type bearings with a Class 3 internal fit conforming to AFBMA Standard 20 are used. The bearings are greased for life with a premium moisture resistant polyurea thickened grease containing rust inhibitors and suitable for operation over a range of - 25° C to + 120° C.

**Impeller Mounting Screw:** 300 series stainless steel with anti-rotational locking patch.

**Castings:** All iron castings are ASTM A48 class 30 gray cast iron. Optional bronze impeller is ASTM B584 C87600 silicon bronze.

- UL (Underwriters Laboratories) Listed Motors.
- Three phase motors only.
- Available voltages: 200, 230, 400, 460 and 575 volt, 60 Hz.
- HP Range: 7.5 - 40
- Motor shaft is a one-piece design of high strength 416 stainless steel.
- All motors are air-filled and designed for continuous duty when fully submerged or for up to 15 minutes operation in air.
- NEMA design "B" with copper windings.
- Class "F" stator winding designed for inverter duty.
- Moisture System: Two wire dual probe monitoring system constantly monitors seal oil chamber and stator housing for moisture. **Note:** control panel must contain an alarm circuit and alarm device.
- Two (2) normally-closed, automatic reset thermostats connected in series and embedded in adjoining phases.
- Power and sensor cords are 25' standard length, 50' available as an option.
- Motors conform to the latest applicable requirements of NEMA, IEEE, ANSI and NEC standards.

**NOTICE:** Class 10 quick trip overload protection must be provided in control panel.

### AGENCY LISTINGS



Tested to UL 778 and CSA 22.2 108 Standards  
By Canadian Standards Association  
File #LR38549

MOTOR LISTED EXPLOSION PROOF  
CLASS I, DIVISION I, GROUPS C & D



Underwriters  
Laboratories

### MODEL AND MOTOR INFORMATION (All ratings at 3 phase, 60 Hz. Consult factory for 3 phase, 50 Hz applications.)

Order Number	HP	Phase	Volts	RPM	Impeller Dia. (In.)	Impeller Code	S.F. Amps	Service Factor	Full Load Amps	Locked Rotor Amps	Power Cable Size	Sensor Cable Size	Frame Size	Weight (lbs.)
4XD12K2MC	7.5	3	200	1750	7.50	M	27.0	1.15	24.2	183.8	8/4	18/5	210TY	455
4XD12K3MC			230				23.4		21.0	160.0	8/4			
4XD12K4MC			460				11.7		10.5	80.0	8/4			
4XD12K5MC			575				9.4		8.4	64.0	14/4			
4XD12L2KC	10		200		8.00	K	35.6		31.1	186.2	8/4			
4XD12L3KC			230				31.0		27.0	162.0	8/4			
4XD12L4KC			460				15.5		13.5	81.0	8/4			
4XD12L5KC			575				12.3		10.8	64.0	14/4			
4XD12M2GC	15		200		9.00	G	54.8		48.2	256.0	6/4			
4XD12M3GC			230				47.8		42.0	222.0	8/4			
4XD12M4GC			460				23.9		21.0	111.0	8/4			
4XD12M5GC			575				19.1		16.8	88.7	10/4			
4XD12N2EC	20		200		9.75	E	74.8		64.4	342.0	4/4			
4XD12N3EC			230				65.0		56.0	298.0	6/4			
4XD12N4EC			460				32.5		28.0	149.0	6/4			
4XD12N5EC			575				26.0		22.4	119.0	10/4			
4XD12P2CC	25	200	10.38	C	83.6	72.5	394.0	2/4						
4XD12P3CC		230			72.8	63.0	342.0	4/4						
4XD12P4CC		460			36.4	31.5	171.0	4/4						
4XD12P5CC		575			29.1	25.2	137.0	8/4						
4XD12Q2BC	30	200	10.75	B	103.2	89.7	472.0	2/4						
4XD12Q3BC		230			89.6	78.0	410.0	2/4						
4XD12Q4BC		460			44.8	39.0	205.0	2/4						
4XD12Q5BC		575			35.8	31.2	164.0	8/4						
4XD12R2AC	40	200	11.00	A	132.8	114.4	600.0	1/0/4						
4XD12R3AC		230			115.4	99.4	522.0	1/4						
4XD12R4AC		460			57.7	49.7	261.0	6/4						
4XD12R5AC		575			46.2	39.8	209.0	8/4						
4XD13K3DC	7.5	1150	200	10.12	D	30.4	26.5	131.6	8/4					
4XD13K4DC			230			26.4	23.0	114.4	10/4					
4XD13K5DC			460			13.2	11.5	57.2	10/4					
4XD13K2DC			575			10.6	9.2	45.8	14/4					
4XD13L2AC	10		200	11.00	A	40.0	35.0	186.0	8/4					
4XD13L3AC			230			34.8	30.4	161.0	8/4					
4XD13L4AC			460			17.4	15.2	80.7	8/4					
4XD13L5AC			575			13.9	12.2	64.5	12/4					

### NOMENCLATURE DESCRIPTION

#### 1<sup>st</sup> Character - Discharge Size

4 = 4" 125 # ANSI Discharge Flange

#### 2<sup>nd</sup> and 3<sup>rd</sup> Character - Pump Type / Design

XD = Explosion Proof, Dual Seal Pump with On-Winding Thermal Sensors and Moisture Detection Sensors

#### 4<sup>th</sup> Character - Mechanical Seals

1 = Standard Seal - the upper seal is carbon/ceramic, the lower seal is carbon/ceramic, BUNA and 304 stainless steel metal parts.

3 = Optional Lower Seal - silicon carbide/silicon carbide, Viton elastomers and 304 SS metal parts.

5 = Optional Lower Seal - silicon carbide/tungsten carbide, Viton elastomers and 304 SS metal parts.

#### 5<sup>th</sup> Character - Motor RPM / Hertz

2 = 1750 RPM / 60 Hz      6 = 1450 RPM / 50 Hz

3 = 1150 RPM / 60 Hz

#### 6<sup>th</sup> Character - Horsepower

K = 7.5    M = 15    P = 25    R = 40

L = 10    N = 20    Q = 30

#### 7<sup>th</sup> Character - Voltage / Phase

2 = 200 / 3      4 = 460 / 3      6 = 380/400 / 3

3 = 230 / 3      5 = 575 / 3

#### 8<sup>th</sup> Character - Impeller Code

A = 11.0"    10 HP 1150 RPM    40 HP 1750 RPM  
20 HP 1450 RPM

B = 10.75"    30 HP 1750 RPM

C = 10.38"    25 HP 1750 RPM

D = 10.12"    7.5 HP 1150 RPM    15 HP 1450 RPM

E = 9.75"    20 HP 1750 RPM

G = 9.00"    15 HP 1750 RPM    10 HP 1450 RPM

K = 8.00"    10 HP 1750 RPM    7.5 HP 1450 RPM

M = 7.50"    7.5 HP 1750 RPM

T = SPECIAL TRIM

#### 9<sup>th</sup> Character - Cord Length - Power and Sensor Cords

C = 25' standard    F = 50' Optional

#### 10<sup>th</sup> Character - Options

B = Silicon Bronze Impeller    E = Epoxy Paint

F = Both Bronze Impeller and Epoxy Paint

## APPLICATION DATA

Maximum Solid Size	3"
Minimum Casing Thickness	5/16"
Casing Corrosion Allowance	1/8"
Maximum Working Pressure	100 PSI
Maximum Submergence	200 feet
Maximum Environmental Temperature	40°C (104°F) ambient conditions
Maximum Starts Per Hour	Maximum of 10 evenly spaced starts per hour

## CONSTRUCTION DETAILS

Power Cable - Type	1/0 / 4, 2/4, 4/4, 6/4, 8/4, 10/4, 12/4 SOW or SOOW (see Model Info)
Control / Sensor Cable / Type	Type 18/5 SOW
Power Cable and Cap Assembly	Leads have a BUNA-N grommet in addition to being epoxy encapsulated
Power and Control Cable Lengths	25' standard, 50' optional
Motor Enclosure	Cast iron ASTM A-48 Class 30
Motor Shaft	Series 416 Stainless steel
Motor Design	NEMA design "B" with copper windings and designed to withstand 200 psi water pressure at all seal locations. Air-filled NEMA 210TY frame on 7.5, 10, 15 and 20 HP models. Air-filled NEMA 250TYS frame on 25 - 40 HP models.
Motor Insulation Rating	Class "F" insulation
Motor Thermal Protection	Two (2) normally closed on-winding thermostats open at 320° F (160° C), automatic reset closes at 221° F (105° C).
Motor Overload Protection	Class 10, ambient compensated, quick-trip overload protection must be provided in control panel.
Motor Moisture Protection	Two (2) moisture sensing probes in the oil-filled seal chamber must be connected to a relay in control panel.
Casing	Cast iron ASTM A-48 Class 30
Impeller	Cast iron ASTM A-48 Class 30 or optional cast bronze ASTM B584 UNS C87600.
Impeller Type	Two vane enclosed design for maximum efficiency.
Casing/Impeller/Wear Ring	Replaceable bronze wear ring
External Hardware	Stainless steel

## STANDARD PARTS

Ball Bearing	Lubricated for life bearings are designed for a minimum L10 life of 30,000 hours.	
210 and 250 Frame		Single row Radial (upper)
		Single row Thrust (lower)
Mechanical Seals - Standard	Upper	Carbon/rotary and ceramic/stationary
	Lower	
Mechanical Seals - Optional	Lower	Silicon carbide/rotary and tungsten carbide/stationary
	Lower	Silicon carbide/rotary and silicon carbide/stationary
Standard Motor O-rings	BUNA-N (nitrile)	
Seal Chamber Oil	Premium moisture resistant polyurea thickened grease containing rust inhibitors is suitable for operation over a temperature range of - 25° C to +120° C.	

## DIMENSIONS

(All dimensions are in inches. Do not use for construction purposes.)

HP	RPM	"A" Dimensions (in.)
7½	1750	41.3
10		
15		
20		
25		
30		
40	1150	46.6
7½		
10		41.3

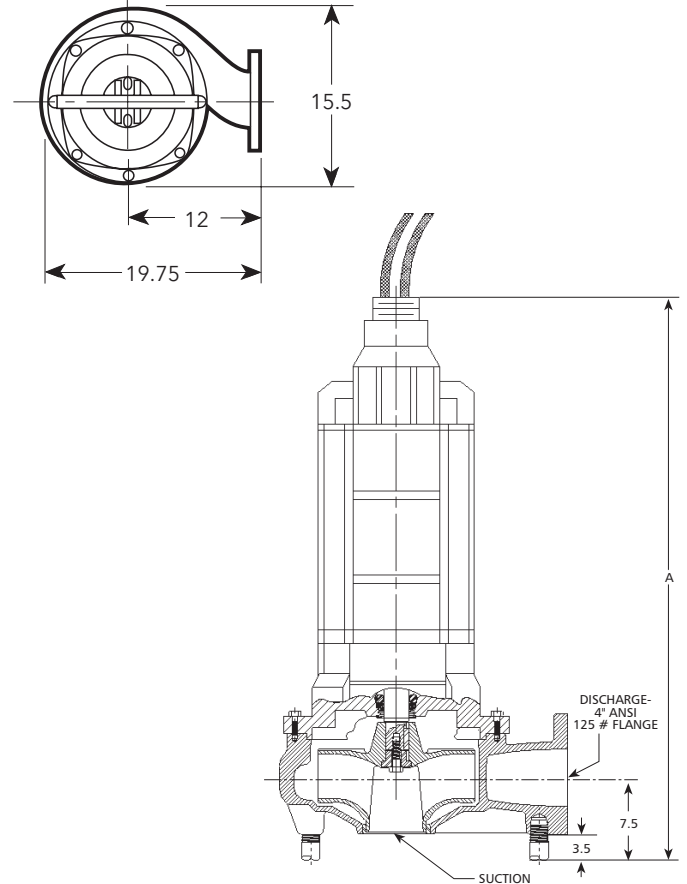

**xylem**  
Let's Solve Water

Xylem, Inc.  
2881 East Bayard Street Ext., Suite A  
Seneca Falls, NY 13148  
Phone: (866) 325-4210  
Fax: (888) 322-5877  
[www.xylem.com/brands/gouldswatertechnology](http://www.xylem.com/brands/gouldswatertechnology)

Goulds is a registered trademark of Goulds Pumps, Inc. and is used under license.  
© 2012 Xylem Inc. B4XD May 2012